

COGNEX

PRODUCT GUIDE 2007

The DataMan 7500 Series.
Rugged ID readers and
verifiers that set the
standard for part traceability.

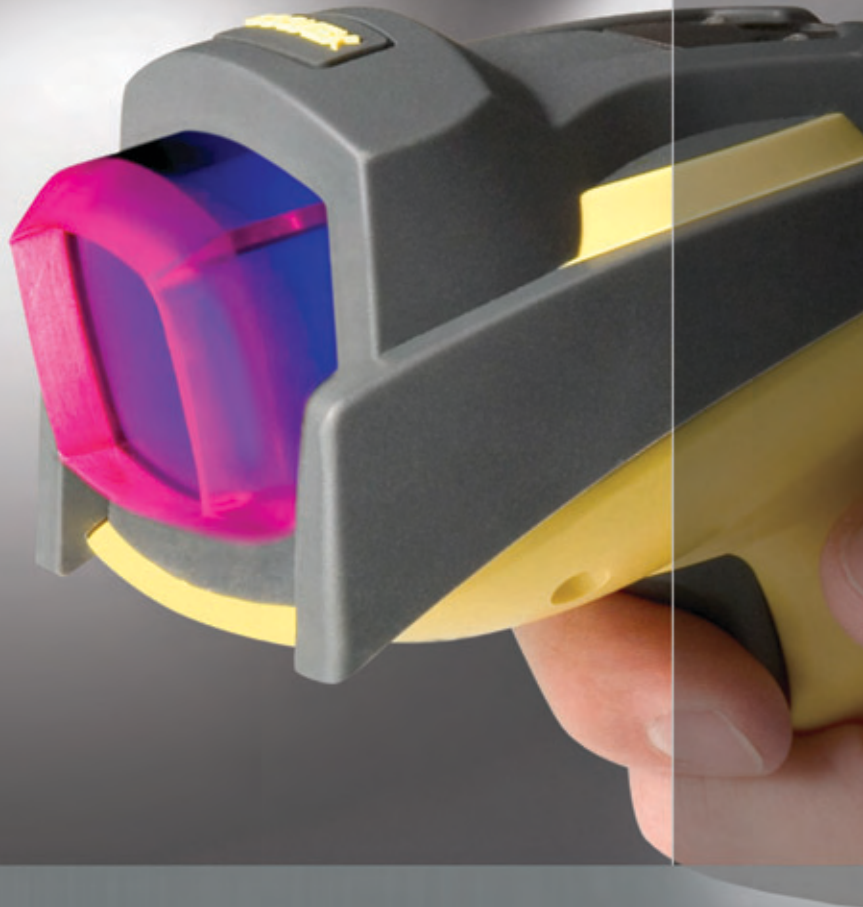

DataMan 7500
ID Readers and Verifiers

Setting the Standard

DataMan™ 7500 Series sets the industry standard for reading and verifying Direct Part Mark (DPM) codes for part traceability.

DPM Identification for part traceability demands rugged, self-contained readers and verifiers that perform consistently on all types of marks and parts. The DataMan 7500 Series readers are the only handheld products in industry that handle everything from the most challenging DPM marks to the easiest printed barcodes ... and provide AIM DPM compliant verification.

The DataMan product family covers all aspects of the DPM ID process ... reading, code quality verification, and DoD validation. And, the DataMan 7500 Series is designed to hold up to the harshest environments... up to 50 drops to concrete from two meters.

When you add industry-leading software to the list of breakthrough features, these readers are the clear choice for the factory floor.

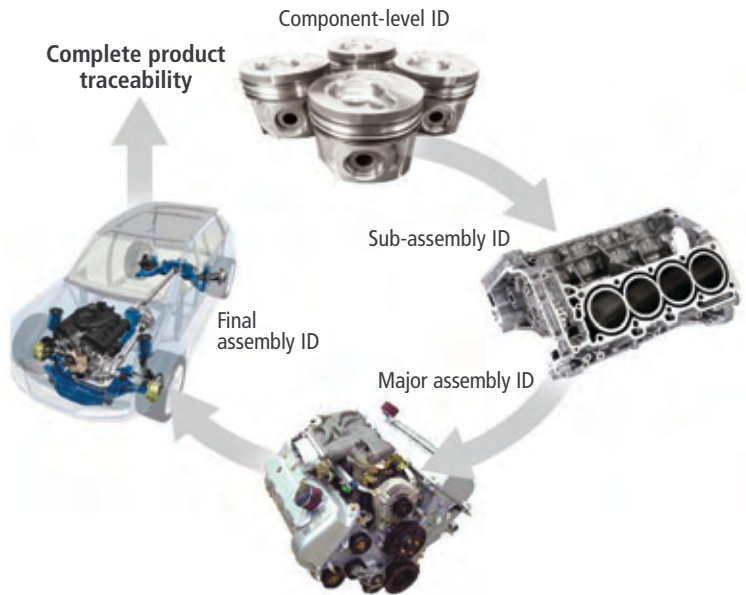

DPM code identification at every step of a part's assembly assures traceability throughout its life.

Bringing DataMan Benefits to Many Industries

This high degree of reliability ensures the economic return required by part traceability objectives.



Automotive Parts

Automotive suppliers use the DataMan 7500 Series throughout the manufacturing process for error proofing and traceability.



DoD

The DataMan 7500 Series supports the DoD and its supply base with Unique Identification (UID) reading, validation, and quality verification.



Aerospace

Data Matrix codes have been adopted by the Aerospace industry to identify and track parts through production, as well as through the life of the parts.



Medical Equipment and Devices

Data Matrix codes support the initiative of Unique Identification Marks (UIM) on medical devices.



Electronic Components

Electronics manufacturers moving from bar code labels to 2D codes (due to space constraints and the need to include more data on parts) use DataMan readers to identify boards and components.

DPM ID Requires Innovation

The DataMan product family incorporates innovative technology for all aspects of the DPM process.

IDMax Reading Software

DataMan readers incorporate IDMax™, a breakthrough in 2D reading software based upon Cognex patented PatMax® technology. IDMax handles a wide range of degradations to the appearance of the code, no matter what the cause, allowing DataMan readers to deliver the industry's most reliable reading within a compact, easy-to-use handheld reader.

UltraLight Illumination

The UltraLight™ illumination system allows DataMan readers to optimally illuminate marks of any type on any surface. Low-angle lighting with quadrant control provides the uniform illumination required for dot peen and laser etch marks. The integrated diffuser provides soft illumination required for highly reflective parts such as electrochemical etched marks on shiny round surfaces. Diffuse bright field illumination provides uniform lighting throughout a wide working range, which is ideal for 1D barcode labels and marks located on recessed surfaces.

Handheld Verifiers

The Cognex DataMan 7500 Series product line is the first to offer a handheld verification solution that meets the requirements of the AIM (Association for Automatic Identification and Mobility) 2D Data Matrix code quality grading requirements. The DataMan Products achieve their breakthrough capability from the innovative combination of lighting, software, and optics and a unique verification accessory. DataMan 7500V Series verifiers produce the reliable, consistent performance necessary for contract-compliant verification, while providing the greatest ease of use available.

UltraLight Illumination System

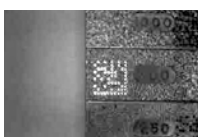

Dark field illumination for dot peen and laser DPM



Diffuse off-axis illumination for curved surfaces and highly-reflective surfaces



Quadrant control for machined surfaces



Diffuse bright field illumination for labels and marks having good contrast

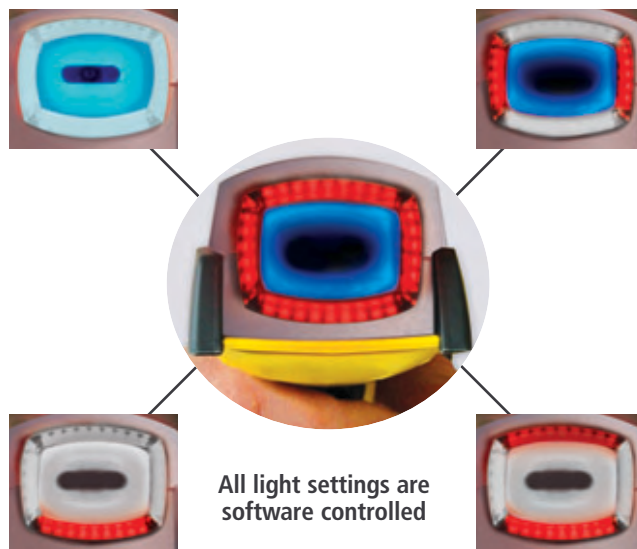

High-Performance Rugged Readers

Products for every step in the DPM process ... reading, verification, and validation.

DataMan Handheld Readers

DataMan 7500 Series readers provide the complete range of products and features for any DPM application. DataMan 7500 and 7550 readers meet the most challenging DPM applications, while the DataMan 7500LR and 7550LR models are ideal for applications requiring a wider field of view or longer reading range. All DataMan 7500 Series readers include the capability of data validation.



The DataMan 7500 Series includes corded and cordless models (shown in the intelligent base station), to provide rugged and reliable code reading solutions for all applications.

Powerful DataMan features include:

- **IDMax decoding software** ... for the highest reading yield on DPM codes
- **UltraLight illumination** ... provides optimal lighting for all mark types and surfaces
- **Autodiscrimination** ... of both 1D and 2D codes
- **Corded and cordless models** ... provide solutions for stationary and mobile reading applications
- **Rugged ergonomic design** ... built for demanding factory floor environments



The combination of the 7500 Series UltraLight technology and ID Max software enables DataMan readers to provide the most reliable DPM read rates in the industry.



DataMan 7500 Series readers include autodiscrimination capability, allowing them to read 1D/2D code combinations automatically, without reader configuration changes.



DataMan 7500LR Series readers have the enhanced capability of reading 1D codes that require a larger field of view, while still providing the industry-leading DPM 2D code-reading capability.

DPM Verification ... Ensuring 2D Code Quality

The easy-to-use and reliable DataMan quality control solution enables extremely high read rates of DPM codes that are critical to product traceability.

An Essential Key to a Successful DPM Identification Process

In order for a DPM product traceability initiative to be successful, the 2D code must be readable throughout the product's life cycle. Direct Part Mark Verification ensures that the quality of a code meets a manufacturer's or industry's requirements for consistent and reliable code reading ... ensuring that parts will not be rejected due to unreadable codes.

To provide contract-compliant DPM verification, a verifier must utilize an industry-wide quality standard that provides repeatability across different verification platforms and manufacturers. The verifier must have the ability to assess a 2D mark using calibrated lighting and optics. The standard used for DPM verification must take into account the range of mark types and part surfaces used for DPM part traceability applications.

The DataMan Advantage

DataMan verifiers enable compliance to AIM* Direct Part Mark (DPM) Quality Guideline DPM1-2006. And now, DataMan brings a "first" to industry ... portability. This enables manufacturers to perform verification on the factory floor, rather than at a fixed verification setup at a remote location. The combination of AIM compliance and portability provides users with advantages that set DataMan verifiers apart from all others.

*Association for Automatic Identification and Mobility.

High-Reliability Portable Verification

DataMan is the only verifier that enables users to accurately verify direct-marked and printed 2D code quality with a completely self-contained handheld unit.



Supports the
AIM Direct Part
Mark Quality
Guideline!

The corded verifier, (7500V) and cordless model (7550V), provide AIM DPM compliant verification with the easiest to use verifiers available in the industry.

DataMan Verifiers feature:

- **AIM DPM compliant** ... software, integrated lighting and fixed optics enable DataMan verifiers to meet AIM Direct Part Mark (DPM) Quality Guideline DPM1-2006
- **Reliable, consistent performance** ... the design of the mechanical standoff used for the verifier ensures uniform illumination and a fixed working distance
- **Calibrated** ... the DataMan verifier includes a NIST SRM-1930-90 certified, and traceable, calibration target necessary to establish AIM DPM reflectance values
- **Ease of Use** ... DataMan portability enables verification on the factory floor, rather than at a remote location
- **Mobile operation** ... the DataMan 7550V cordless model can be brought directly to the part, especially useful for larger parts
- **Quick and cost-effective part changeovers** ... no need to adjust benchtop fixturing or lighting when the production line changes

Validating ... With DataMan Readers

DataMan 7500 Series readers also provide the capability to validate the data content of a code according to published International and Industry standards.

Many industries have now adopted the ISO 15434 standard for data structure for high capacity codes. In addition, the ISO 15418 standard is now used to identify data elements with universally understood Data Qualifiers.

The U.S. Department of Defense has adopted both the ISO 15434 and ISO 15418 standards as part of its UID (Unique Identification) program for parts in the U.S. Department of Defense inventory. In addition, the U.S. Department of Defense has defined a specific structure for data included in UID codes in accordance with ISO 15434 and ISO 15418 requirements.

DataMan 7500 Series readers ensure that data within a code meets the standards as outlined by ISO 15434, ISO 15418 and the U.S. Department of Defense.

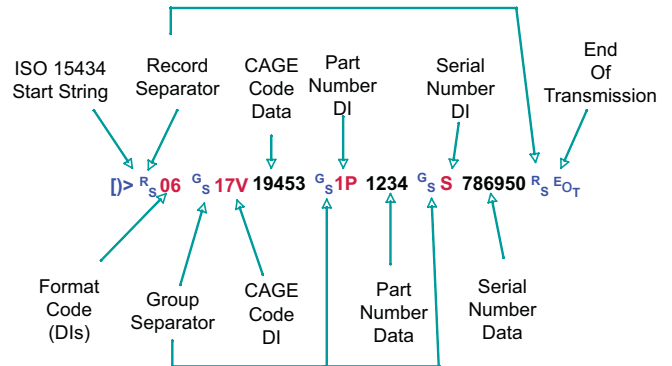

Equals a UID of D194531234786950

An example of data validation on a UID code performed by DataMan handheld readers.

Verification and Validation Software Features

Powerful software simplifies initial reader setup, data validation, and code quality verification.

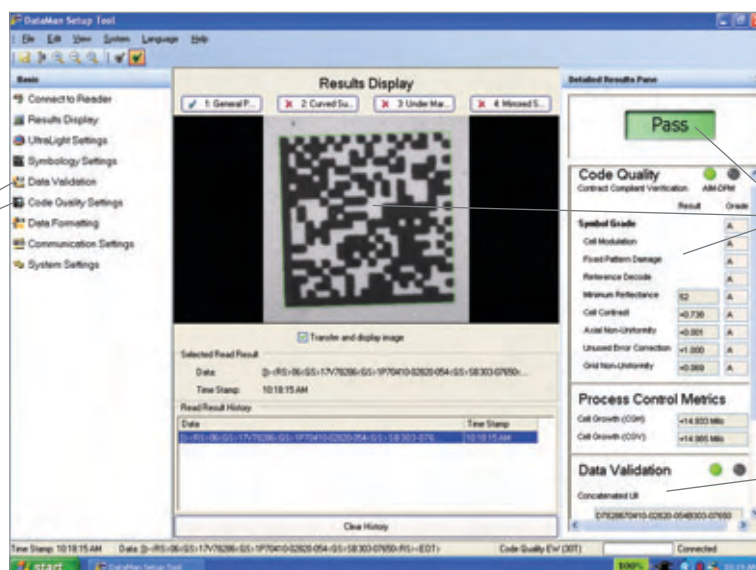

The software enables users to quickly select the desired validation and verification features.

When AIM DPM compliant verification is enabled, the software provides overall and detailed metric results, as well as graphical image feedback.

Validation features provide detailed feedback on code content and the data format correctness.

Verifier Setup tool

Accessories for DataMan Versatility

A wide range of accessories adds exceptional convenience and versatility to DataMan 7500 Series readers and verifiers.

Retractors

Overhead Retractor

Hook easily attaches to any overhead structure



The retractor provides convenient access to DataMan readers and verifiers from an overhead storage position, and also prevents accidental dropping of the reader.

Belt Retractor



Consisting of an adjustable-waist belt and retractor, this accessory allows easy access to the DataMan reader or verifier. It also provides a holding position for the reader as the operator moves throughout the plant.

Spare Battery Charging Sleeve



The charging sleeve holds a spare battery for use with wireless DataMan models. The sleeve, with battery, can be placed in the DataMan base station while the reader is in use ... or in an optional charge-only base station, ensuring that a backup battery is always available.

Storage/holders

Wall-Mount Holder



The Wall-Mount Holder allows easy storage of DataMan readers. Hardware for mounting to metal, drywall, and wooden surfaces is included.

Presentation Stand



The presentation stand provides tabletop DataMan storage ... and its flexible neck makes it ideal for presentation mode scanning. Included is a weighted base, flexible neck, and the same mounting bracket used in the wall-mount holder accessory.

Specifications

ID TOOLS

2D	Data Matrix, QR Code, MicroQR Code
Bar code	EAN13, UPC-A, EAN8, UPC-E, Interleaved 2 of 5, Code 39, Code 128, Code 93

VERIFICATION STANDARDS

AIM DPM Mark Quality Standard

IMAGE

Sensor	1280 x 960 high-resolution pixel array
--------	--

LIGHTING/OPTICS

Illumination	Integrated diffuser; bright- and dark-field LED's
Reading direction	Omni-directional, pitch and skew (off-axis) angles up to 35 degrees
Aiming	Horizontal green light bar aimed at center of field of view

I/O

Trigger	Via trigger switch in the handle
Additional outputs	Multifunctional LED and beeper to indicate good read, device status, or errors

COMMUNICATIONS

Interfaces	
7500/7500LR/7500V	USB and/or RS-232 for data communication, set-up, and image preview. PS2 keyboard wedge, PS2 or USB keyboard emulation

COMMUNICATIONS (cont.)

7550/7550LR/7550V	Reader to base station: Bluetooth class 2 (10m range) Base station to PC: USB/RS-232/PS2
-------------------	--

POWER

Electrical requirements	
7500/7500LR/7500V	5VDC, 5 watts
7550/7550LR/7550V	9VDC, 18 watts

Battery	
7550/7550LR/7550V	Eight hours normal use fully charged at 25°C (77°F)

MECHANICAL

Dimensions*	Height: 175mm (6.9in) Width: 134mm (5.3in) Depth: 81mm (3.3in)
Verifier standoff depth	15mm (0.6in)
Material	Polycarbonate housing with shock-absorbing rubber overmold

Weight	
7500/7500LR/7500V**	270g (9.6oz)
7550/7550LR/7550V**	Reader (with battery): 330g (11.7oz) Base: 250g (8.8oz)

* Orientation with camera axis horizontal, verifier standoff not attached
** Verifier standoff not attached. Additional verifier standoff weight: 15g (.48oz)

ENVIRONMENTAL

Operating temperature	
7500/7500LR/7500V	-10°C to +50°C (14°F to +122°F)
7550/7550LR/7550V	0°C to +50°C (32°F to +122°F)
Storage temperature	
7500/7500LR/7500V	-40°C to +70°C (-40°F to +158°F)
7550/7550LR/7550V	-40°C to +60°C (-40°F to +140°F)
Charging temperature	0°C to +40°C (32°F to +104°F)
Operating humidity	0% – 95%, non-condensing
Storage humidity	0% – 95% non-condensing
Drop test	
7500/7500LR/7500V*	50 drops from 2 meters onto concrete
7550/7550LR/7550V*	25 drops from 2 meters onto concrete * Verifier standoff not attached.
Certifications	CE, (FCC, UL, and CSA pending) Please check with your Cognex sales engineer regarding the regulatory status of models 7550 and 7550LR in countries other than the US, Europe, Japan and Canada.
IP rating	Reader: IP54 Base station: IP41

SYSTEM REQUIREMENTS

Microsoft Windows XP, 64MB of memory (RAM)

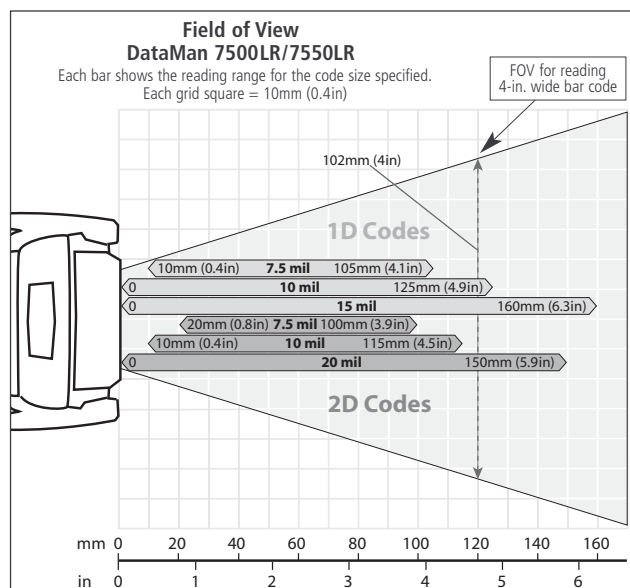
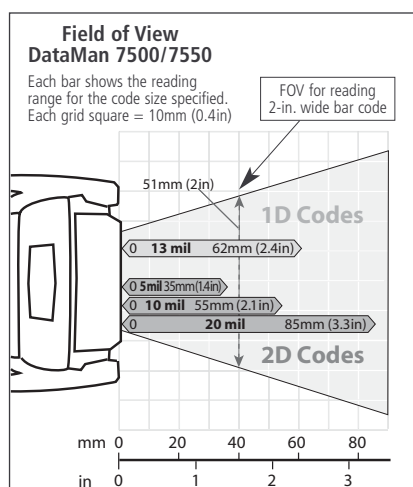

COGNEX

Corporate Headquarters
Cognex Corporation
One Vision Drive
Natick
MA 01760-2059
USA
Tel: 508-650-3000
Fax: 508-650-3344
www.cognex.com

United States

Natick, Massachusetts
Nashville, Tennessee
Detroit, Michigan
Chicago, Illinois
Mountain View, California

www.cognex.com

508-650-3000
615-844-6158
248-668-5100
630-649-6300
650-969-4812

Europe

France
Germany
Ireland
Italy
Netherlands
Spain
Sweden
Switzerland
United Kingdom

www.cognex.net

+33 1 4777 1550
+49 721 6639 0
+353 1 825 4420
+39 02 6747 1200
+31 402 668 565
+34 93 445 67 78
+46 21 14 55 88
+41 71 313 06 05
+44 1908 206 000

Canada

905-634-2726
www.cognex.co.jp
+81 3 5977 5400
www.cognex.net
+86 21 6320 3821
+82 2 539 9047
+65 632 55 700
+886 3 578 0060

Japan

Asia
China
Korea
Singapore
Taiwan